

4.1 Introduction

To study and examine a control system, it is necessary to have some type of equivalent representation of the system. Such a representation can be obtained from the mathematical equations, governing the behaviour of the system. Most of such mathematical equations are differential equations whether the system may be electrical, mechanical, thermal, hydraulic etc.

Key Point *The set of mathematical equations, describing the dynamic characteristics of a system is called **mathematical model** of the system.*

Obtaining the mathematical model is the first step in analysing a given system. In the mathematical model, the various operations in the system are represented by the mathematical equations.

Most of the control systems contain mechanical or electrical or both types of elements and components. To analyse such systems, it is necessary to convert such systems into mathematical models based on transfer function approach. From mathematical angle of view, models of mechanical and electrical components are exactly analogous to each other. Not only this but we can show that for given mechanical system there is always an analogous electrical network exists and vice versa. The mathematical equations describing both the systems are exactly same in nature.

As we are well familiar with the behaviour of electrical networks and methods of writing equations for it, it will be better if we can draw equivalent electrical networks for given mechanical systems. This will help us in writing system equations in simplified manner and with more detailed understanding.

This chapter explains the concept of analogous networks, method of writing differential equations for various physical systems and derives the transfer functions of various commonly used control systems.

Review Question

1. *What is mathematical modeling?*

4.2 Analysis of Mechanical Systems

In mechanical systems, motion can be of different types i.e. Translational, Rotational or combination of both. The equations governing such motion in mechanical systems are often directly or indirectly governed by **Newton's laws of motion**.

The equilibrium equations for the linear mechanical systems can be obtained using **D'Alembert's principle** which states that,

'For any body, the algebraic sum of externally applied forces and the forces resisting the motion in any given direction is zero'.

4.2.1 Translational Motion

Consider a mechanical system in which motion is taking place along a straight line. Such systems are of translational type. These systems are characterised by displacement, linear velocity and linear acceleration.

Key Point According to Newton's law of motion, sum of forces applied on rigid body or system must be equal to sum of forces consumed to produce displacement, velocity and acceleration in various elements of the system.

The following elements are dominantly involved in the analysis of translational motion systems.

- i) Mass ii) Spring iii) Friction.

4.2.2 Mass (M)

This is the property of the system itself which stores the kinetic energy of the translational motion. Mass has no power to store the potential energy. It is measured in kilograms (kg). The displacement of mass always takes place in the direction of the applied force results in inertial force. This force is always proportional to the acceleration produced in mass (M) by the applied force.

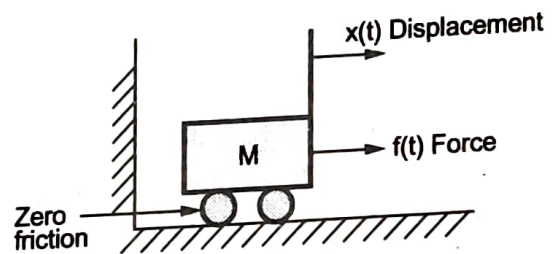

Fig. 4.2.1

Consider a mass 'M' as shown in the Fig. 4.2.1 having zero friction with surface, shown by rollers.

The applied force $f(t)$ produces displacement $x(t)$ in the direction of the applied force $f(t)$. Force required for the same is proportional to acceleration.

$$\therefore f(t) = M \times \text{Acceleration} = M \frac{d^2x(t)}{dt^2}$$

Taking Laplace and neglecting initial conditions we can write,

$$F(s) = Ms^2 X(s)$$

Also mass cannot store potential energy so there cannot be consumption of force in the mass e.g. if two masses are directly connected to each other as shown in the Fig. 4.2.2 and if force $f(t)$ is applied to mass M_1 then mass M_2 will also displace by same amount as M_1 .

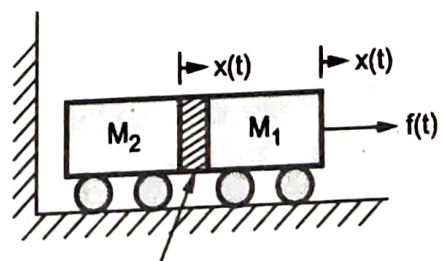

Rigid connection
(No friction and no elastic action)

Fig. 4.2.2

Due to mass, there cannot be any change in force from one mass to other hence no change in displacement.

Key Point The displacement of rigidly connected masses is always same.

4.2.3 Linear Spring

In actual mechanical system there may be an actual spring or indication of spring action because of elastic cable or a belt. Now spring has a property to store the potential energy. The force required to cause the displacement is proportional to the net displacement in the spring. All springs are basically nonlinear in nature but for small deformations their behaviours can be approximated as linear one. Hence assuming linear spring constant 'K' for the spring, we can write equation for the spring in the system.

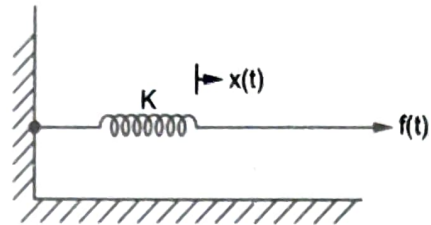

Fig. 4.2.3

Consider a spring having negligible mass and connected to a rigid support. Its spring constant be 'K' as shown in the Fig. 4.2.3.

∴ Force required to cause displacement $x(t)$ in the spring is proportional to displacement.

$$f(t) = K x(t)$$

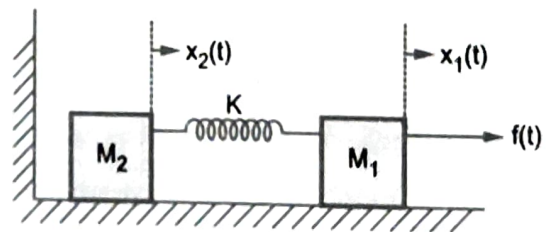

Fig. 4.2.4

Now consider the spring connected between the two moving elements having masses M_1 and M_2 as shown in the Fig. 4.2.4 where force is applied to mass M_1 .

Now mass M_1 will get displaced by $x_1(t)$ but mass M_2 will get displaced by $x_2(t)$ as spring of constant K will store some potential energy and will be the cause for change in displacement. Consider free body diagram of spring as shown in the Fig. 4.2.5.

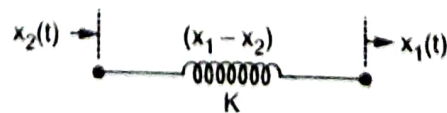

Fig. 4.2.5 Spring between two moving points causes change in displacement

Net displacement in the spring is $x_1(t) - x_2(t)$ and opposing force by the spring is proportional to the net displacement i.e. $x_1(t) - x_2(t)$

∴

$$F_{\text{spring}} = K[x_1(t) - x_2(t)]$$

Taking Laplace,

$$F_{\text{spring}} = K[X_1(s) - X_2(s)]$$

Key Point The spring between the moving points causes a change in displacement from one point to another.

Spring behaves exactly same in rotational systems, only the linear spring constant becomes torsional spring constant but denoted as 'K' only.

4.2.4 Friction

Whenever there is a motion, there exists a friction. Friction may be between moving element and fixed support or between two moving surfaces. Friction is also nonlinear in nature. It can be divided into three types,

- i) Viscous friction ii) Static friction iii) Coulomb friction

Viscous friction as dominant out of the three is generally considered, neglecting other two types. Viscous friction is assumed to be linear with frictional constant 'B'. This has linear relationship with relative velocity between two moving surfaces.

The friction is generally shown by a dash-pot or a damper as shown in the Fig. 4.2.6.

This is the symbolic representation of a friction.

Consider a mass M as shown in the Fig. 4.2.7 having friction with a support with a constant 'B' represented by a dash-pot.

Friction will oppose the motion of mass M and opposing force is proportional to velocity of mass M.

∴

$$F_{\text{frictional}} = B \frac{dx(t)}{dt}$$

Taking Laplace and neglecting initial conditions,

$$F_{\text{frictional}}(s) = Bs X(s)$$

Similarly if friction is between two moving surfaces, it is shown in the Fig. 4.2.8.

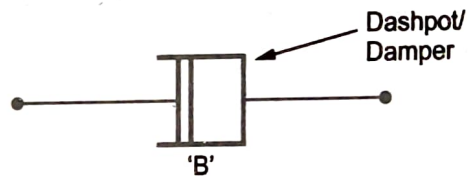

Fig. 4.2.6

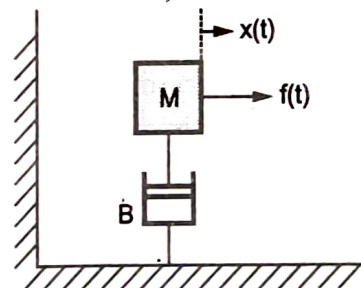

Fig. 4.2.7

In such a case, opposing force is given by,

$$F_{\text{frictional}} = B \left[\frac{dx_1(t)}{dt} - \frac{dx_2(t)}{dt} \right]$$

Taking Laplace,

$$F_{\text{frictional}}(s) = Bs [X_1(s) - X_2(s)]$$

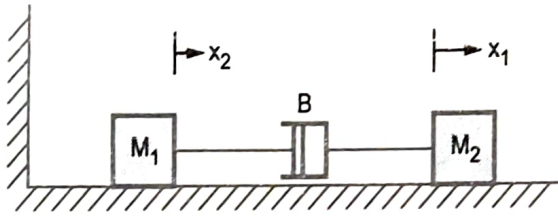

Fig. 4.2.8 Friction between two moving points causes change in displacement

Thus if the force applied to mass M_2 is $f(t)$ then due to friction between the masses M_1 and M_2 , the force getting transmitted to M_1 is always less than $f(t)$. Hence the displacement of mass M_1 is different than the displacement of mass M_2 .

Key Point *The friction between two moving points, causes a change in displacement from one point to other.*

Frictional force also behaves exactly in same manner, in rotational systems, only linear frictional constant becomes torsional frictional constant but denoted by same symbol 'B' only.

The other two types of friction are,

1. The **static friction** is the friction which exists when there is no motion and it tends to prevent the start of the motion. Once the motion begins, then the static friction vanishes and other frictions come into the play. Mathematically it is represented as,

$$F_{\text{friction}} = \pm F_s \Big|_{\dot{x}=0}$$

$\dot{x} = 0$ indicates that velocity is zero and the movement is just going to begin.

2. The **coulomb friction** has a constant magnitude with respect to the change of velocity. The sign of this frictional force changes as the direction of velocity changes.

Mathematically it is represented as,

$$F_{\text{friction}} = F_c \frac{\left(\frac{dx(t)}{dt} \right)}{\left| \frac{dx(t)}{dt} \right|}$$

where F_c is called Coulomb friction coefficient. The Fig. 4.2.9 shows the graph of frictional force against velocity for the three types of frictions.

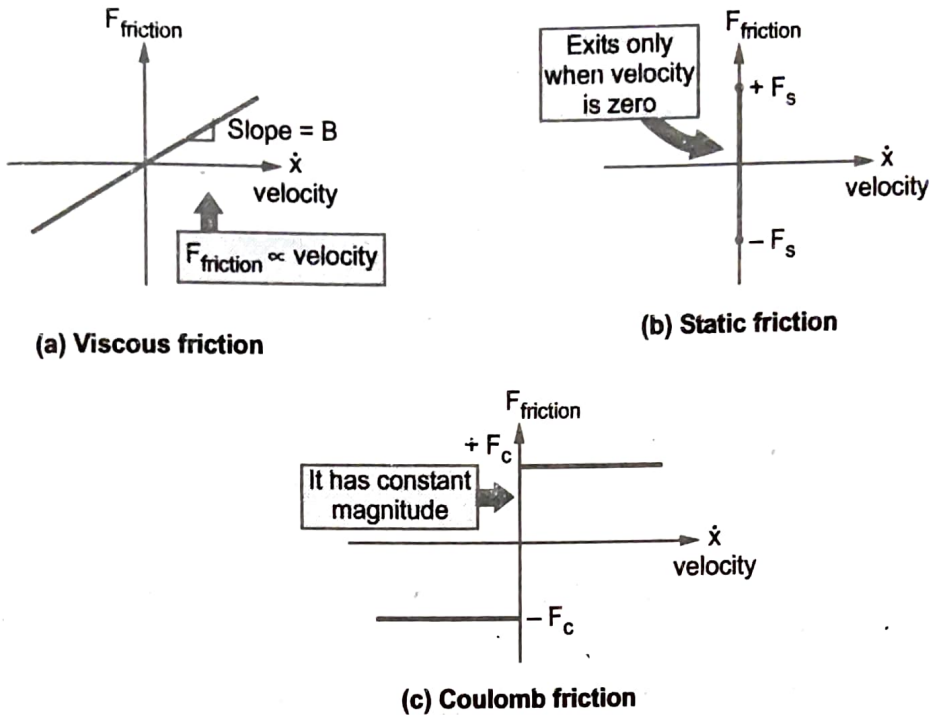

Fig. 4.2.9 Types of frictions

Review Question

1. Explain the mathematical modeling of fundamental components of mechanical translations system.

4.3 Rotational Motion

June-07

This is the motion about a fixed axis. In such systems, the force gets replaced by a moment about the fixed axis i.e. (force \times distance from fixed axis) which is called Torque.

So extension of Newton's law states that the sum of the torques applied to a rigid body or a system must be equal to sum of the torques consumed by the different elements of the system in order to produce angular displacement (θ), angular velocity (ω) and angular acceleration (α) in them. As previously stated, spring and friction behaves in same manner in rotational systems. The property of system which stores kinetic energy in rotational system is called **Inertia** and denoted by 'J' i.e. moment of inertia. Opposing torque due to inertia 'J' is proportional to the angular acceleration (α) of that inertia.

$$\therefore T_{\text{due to inertia}} = J \frac{d^2\theta(t)}{dt^2} \quad \text{where } \alpha = \frac{d^2\theta}{dt^2}$$

Taking Laplace,

$$T_{\text{due to inertia}}(s) = J s^2 \theta(s)$$

Sr. No.	Translational motion	Rotational motion
1.	Mass (M)	Inertia (J)
2.	Friction (B)	Friction (B)
3.	Spring (K)	Spring (K)
4.	Force (F)	Torque (T)
5.	Displacement (x)	Angular displacement (θ)
3.	Velocity $v = \left(\frac{dx}{dt}\right)$	Angular velocity $\left(\omega = \frac{d\theta}{dt}\right)$
7.	Acceleration $\left(\frac{d^2x}{dt^2}\right)$	Angular acceleration $\left(\alpha = \frac{d^2\theta}{dt^2}\right)$

Table 4.3.1 Analogous elements

Review Question

1. Explain the mathematical modeling of fundamental components of mechanical rotational system.

June-07, Marks 5

4.4 Equivalent Mechanical System (Node Basis)

While drawing analogous networks, it is always better to draw the equivalent mechanical system from the given mechanical system. To draw such system use following steps :

- Step 1 : Due to applied force, identify the displacements in the mechanical system.
- Step 2 : Identify the elements which are under the influence of different displacements.
- Step 3 : Represent each displacement by a separate node, using Nodal Analysis.
- Step 4 : Show all the elements in parallel under the respective nodes which are under the influence of respective displacements.
- Step 5 : Elements causing same change in displacement will get connected in parallel in between the respective nodes.

4.4.1 Remarks on Nodal Method

a) The terms for an element connected to a node 'x' and stationary surface (reference) is,

For mass $\rightarrow M \frac{d^2x}{dt^2}$
 For friction $\rightarrow B \frac{dx}{dt}$
 For spring $\rightarrow Kx$

b) The term for an element connected between the two nodes 'x₁' and 'x₂' i.e. between two moving surfaces is,

For friction $\rightarrow B \left[\frac{dx_1}{dt} - \frac{dx_2}{dt} \right]$
 For spring $\rightarrow K [x_1 - x_2]$

No mass can be between the two nodes as due to mass there cannot be change in force as mass cannot store potential energy.

c) All elements which are under the influence of same displacement get connected in parallel under that node indicating the corresponding displacement.

e.g. consider the part of the system, shown in the Fig. 4.4.2 (a).

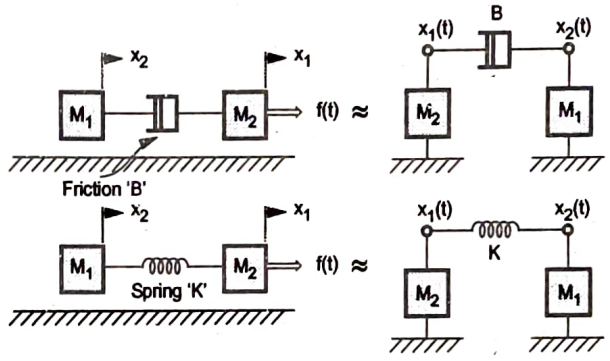
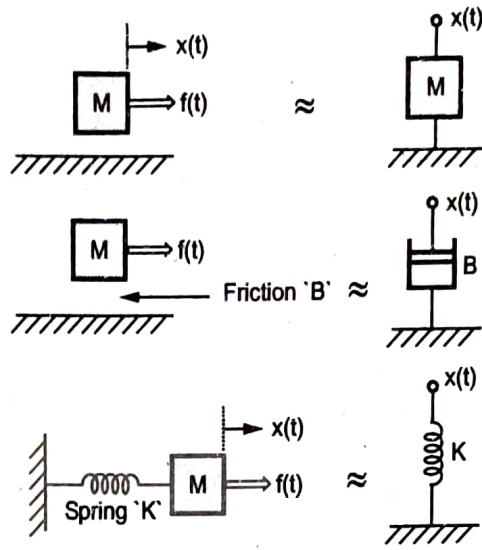

Fig. 4.4.1

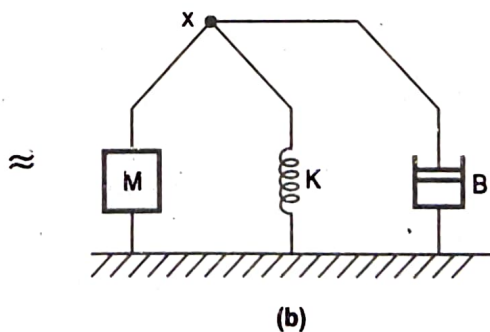
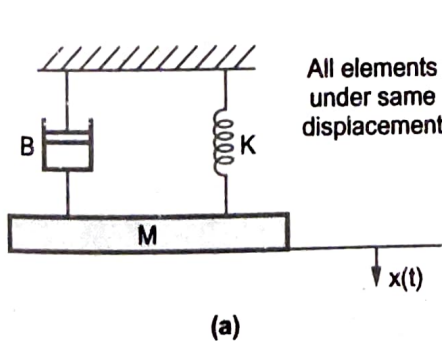

Fig. 4.4.2

Here M , B and K all are under the influence of $x(t)$. Hence in equivalent system all of them will get connected in parallel under the node 'x'. Consider another example of the system shown in the Fig. 4.4.3. In this system M_1 , B_1 and K_1 all are under the influence of displacement x_1 . This is because all are connected to rigid support.

While there is change from x_1 to x_2 due to simultaneous effect of B_2 and K_2 . So B_2 and K_2 are under the influence of $(x_1 - x_2)$. But mass M_2 is under the influence of x_2 alone. Mass cannot be under the influence of difference between displacements. So in equivalent system the elements B_1, K_1 and M_1 , all in parallel under x_1 while B_2 and K_2 in parallel between x_1 and x_2 and element M_2 is under node x_2 as shown in the Fig. 4.4.3 (a).

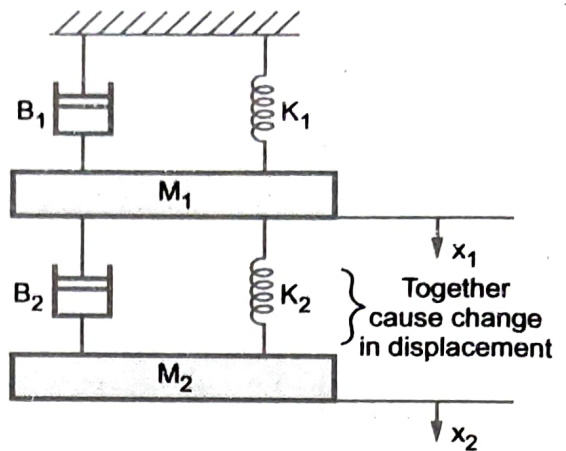

Fig. 4.4.3

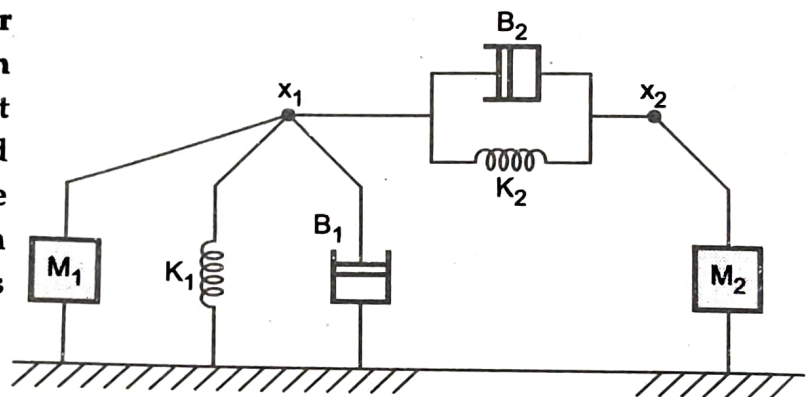

Fig. 4.4.3 (a)

4.5 Electrical Systems

Similar to the mechanical systems, very commonly used systems are of electrical type. The behaviour of such systems is governed by Ohm's law. The dominant elements of an electrical system are,

- i) Resistor ii) Inductor iii) Capacitor.

i) **Resistor** : Consider a resistance carrying current I as shown, then the voltage drop across it can be written as,

$$V = IR$$

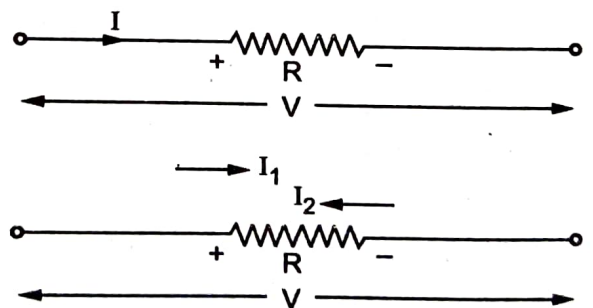

Fig. 4.5.1

Suppose it carries a current $(I_1 - I_2)$ then for the polarity of the voltage drop shown its equation is,

$$V = (I_1 - I_2) R$$

ii) **Inductor** : Consider an inductor carrying current 'I' as shown, then the voltage drop across it can be written as,

$$V = L \frac{dI}{dt} \quad \text{or}$$

$$I = \frac{1}{L} \int V dt$$

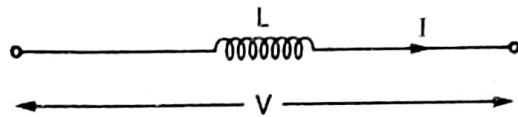

Fig. 4.5.2

If it carries a current $(I_1 - I_2)$ then for the polarity shown its voltage equation is ,

$$V = L \frac{d(I_1 - I_2)}{dt}$$

or

$$(I_1 - I_2) = \frac{1}{L} \int V dt$$

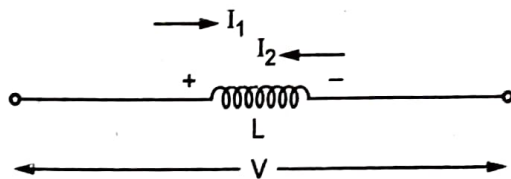

Fig. 4.5.3

iii) **Capacitor** : Consider a capacitor carrying current 'I' as shown, then the voltage drop across it can be written as,

$$V = \frac{1}{C} \int I dt$$

or

$$I = C \frac{dV}{dt}$$

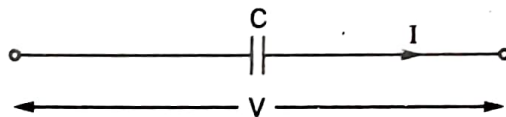

Fig. 4.5.4

If it carries a current $(I_1 - I_2)$ then for the polarity shown its voltage equation is,

$$V = \frac{1}{C} \int (I_1 - I_2) dt$$

or

$$(I_1 - I_2) = C \frac{dV}{dt}$$

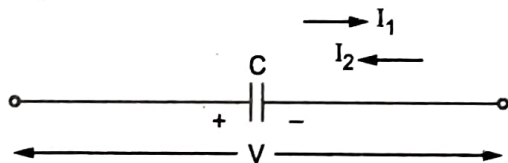

Fig. 4.5.5

4.6 Analogous Systems

Jan.-11

In between electrical and mechanical systems there exists a fixed analogy and their exists a similarity between their equilibrium equations. Due to this, it is possible to draw an electrical system which will behave exactly similar to the given mechanical system, this is called electrical analogous of given mechanical system and vice versa. It is always advantageous to obtain **electrical analogous** of the given mechanical system as we are well familiar with the methods of analysing electrical network than mechanical systems.

There are two methods of obtaining electrical analogous networks, namely

- 1) Force - Voltage Analogy i.e. Direct Analogy.
- 2) Force - Current Analogy i.e. Inverse Analogy.

4.6.1 Mechanical System

Consider simple mechanical system as shown in the Fig. 4.6.1.

Due to the applied force, mass M will displace by an amount $x(t)$ in the direction of the force $f(t)$ as shown in the Fig. 4.6.1.

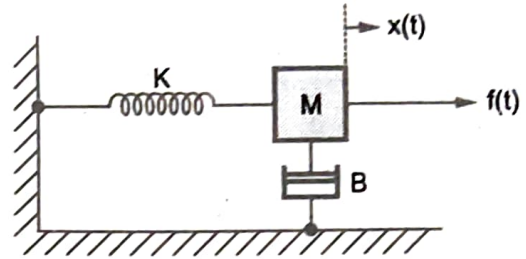

Fig. 4.6.1

According to Newton's law of motion, applied force will cause displacement $x(t)$ in spring, acceleration to mass M against frictional force having constant B .

$$\therefore f(t) = Ma + Bv + Kx(t)$$

where, $a = \text{Acceleration}$, $v = \text{Velocity}$

$$\therefore f(t) = M \frac{d^2 x(t)}{dt^2} + B \frac{dx(t)}{dt} + Kx(t)$$

Taking Laplace, $F(s) = Ms^2 X(s) + Bs X(s) + K X(s)$

This is equilibrium equation for the given system.

Now we will try to derive analogous electrical network.

4.6.2 Force Voltage Analogy (Loop Analysis)

In this method, to the force in mechanical system, voltage is assumed to be analogous one. Accordingly we will try to derive other analogous terms. Consider electric network as shown in the Fig. 4.6.2.

The equation according to Kirchhoff's law can be written as,

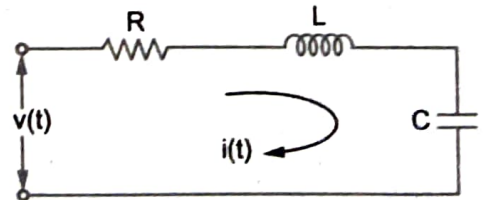

Fig. 4.6.2

$$v(t) = i(t)R + L \frac{di(t)}{dt} + \frac{1}{C} \int i(t) dt$$

Taking Laplace, $V(s) = I(s) R + Ls I(s) + \frac{I(s)}{sC}$

But we cannot compare $F(s)$ and $V(s)$ unless we bring them into same form. For this we will use current as rate of flow of charge.

$$\therefore i(t) = \frac{dq}{dt} \quad \text{i.e. } I(s) = s Q(s) \quad \text{or } Q(s) = \frac{I(s)}{s}$$

Replacing in above equation,

$$V(s) = L s^2 Q(s) + R s Q(s) + \frac{1}{C} Q(s)$$

Comparing equations for $F(s)$ and $V(s)$ it is clear that,

- i) Inductance 'L' is analogous to mass M.
- ii) Resistance 'R' is analogous to friction B.
- iii) Reciprocal of capacitor i.e. $1/C$ is analogous to spring of constant K.

Translational	Rotational	Electrical
Force	Torque T	Voltage V
Mass M	Inertia J	Inductance L
Friction constant B	Tortional friction constant B	Resistance R
Spring constant K N/m	Tortional spring constant K Nm/rad	Reciprocal of capacitor $1/C$
Displacement 'x'	θ	Charge q
Velocity $\dot{x} = \frac{dx}{dt}$	$\dot{\theta} = \frac{d\theta}{dt} = \omega$	Current $i = \frac{dq}{dt}$

Table 4.6.1 Tabular form of force-voltage analogy

Key Point As $i = \dot{q} = \frac{dq}{dt}$, the displacement x is replaced by $\int i dt$ rather than q , in equations.

4.6.3 Force Current Analogy (Node Analysis)

In this method, current is treated as analogous quantity to force in the mechanical system. So force shown is replaced by a current source in the system shown in the Fig. 4.6.3.

The equation according to Kirchhoff's current law for above system is,

$$I = I_L + I_R + I_C$$

Let node voltage be V ,

$$\therefore I = \frac{1}{L} \int V dt + \frac{V}{R} + C \frac{dV}{dt}$$

Taking Laplace,

$$I(s) = \frac{V(s)}{sL} + \frac{V(s)}{R} + sC V(s)$$

But to get this equation in the similar form as that of $F(s)$ we will use,

$$v(t) = \frac{d\phi}{dt} \quad \text{where } \phi = \text{flux}$$

$$\therefore V(s) = s\phi(s) \quad \text{i.e. } \phi(s) = \frac{V(s)}{s}$$

Substituting in equation for $I(s)$

$$I(s) = Cs^2\phi(s) + \frac{1}{R}s\phi(s) + \frac{1}{L}\phi(s)$$

Comparing equations for $F(s)$ and $I(s)$ it is clear that,

- i) Capacitor 'C' is analogous to mass M.
- ii) Reciprocal of resistance $\frac{1}{R}$ is analogous to frictional constant B.
- iii) Reciprocal of inductance $\frac{1}{L}$ is analogous to spring constant K.

Translational	Rotational	Electrical
F Force	T	Current I
M Mass	J	C
B friction	B	1/R
K Spring	K	1/L
x displacement	θ	ϕ
\dot{x} Velocity = $\frac{dx}{dt}$	$\dot{\theta} = \frac{d\theta}{dt} = \omega$	Voltage 'v' = $\frac{d\phi}{dt}$

Table 4.6.2 Tabular form of force-current analogy

Key Point As $\dot{x} = \text{Voltage} = \frac{dx}{dt}$, the displacement x is replaced by $\int v dt$ rather than ϕ , in equations.

Key Point The elements which are in series in F - V analogy, get connected in parallel in F - I analogous network and which are in parallel in F - V analogy, get connected in series in F - I analogous network.

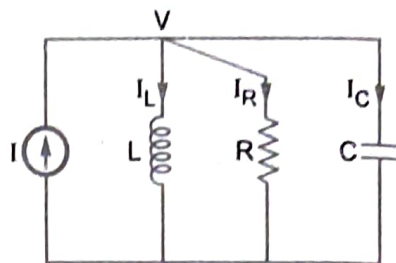

Fig. 4.6.3

Review Questions

- Discuss the force current analogy in brief. State the analogous terms based on force-current analogy.
- Derive the electrical analogous quantities for the mechanical quantities using Force-voltage analog.

Jan.-11, Marks 5

4.7 Steps to Solve Problems on Analogous Systems

Aug-97, 10, Dec.-98, 11, April-99, March-02, Feb.-04, July-05, 06, 08, 09, 10, 11, 12, 13, 14, 15, 16, Jan.-06, 07, 09, 10, 14, 15, 16

Step 1 : Identify all the displacements due to the applied force. The elements spring and friction between two moving surfaces cause change in displacement.

Step 2 : Draw the equivalent mechanical system based on node basis. The elements under same displacement will get connected in parallel under that node. Each displacement is represented by separate node. Element causing change in displacement (either friction or spring) is always between the two nodes.

Step 3 : Write the equilibrium equations. At each node algebraic sum of all the forces acting at the node is zero.

Step 4 : In F-V analogy, use following replacements and rewrite equations,

$$F \rightarrow V, \quad M \rightarrow L, \quad B \rightarrow R, \quad K \rightarrow 1/C, \quad x \rightarrow q, \quad \dot{x} \rightarrow i \text{ (current)}, \quad x \rightarrow \int i \, dt$$

Step 5 : Simulate the equations using loop method. Number of displacements equal to number of loop currents.

Step 6 : In F-I analogy, use following replacements and rewrite equations,

$$F \rightarrow I, \quad M \rightarrow C, \quad B \rightarrow 1/R, \quad K \rightarrow 1/L, \quad x \rightarrow \phi, \quad \dot{x} = e \text{ (e.m.f.)}, \quad x \rightarrow \int e \, dt$$

Step 7 : Simulate the equations using node basis. Number of displacements equal to number of node voltages. Infact the system will be exactly same as equivalent mechanical system obtained in step 2 with appropriate replacements.

Example 4.7.1 For the physical system shown draw its equivalent system and write equilibrium equations. Hence draw its electrical analogous circuits based on
i) Force - Voltage ii) Force - Current method.

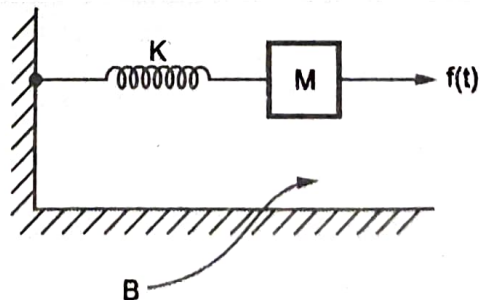

Solution : Mass 'M' will displace by amount 'x' and as spring is connected to fixed support and friction 'B' is also with respect to fixed support, both K and B will be under influence of 'x' only. Now its equivalent system will contain one node and as all elements are under influence of x(t) alone, must be connected in parallel under that node.

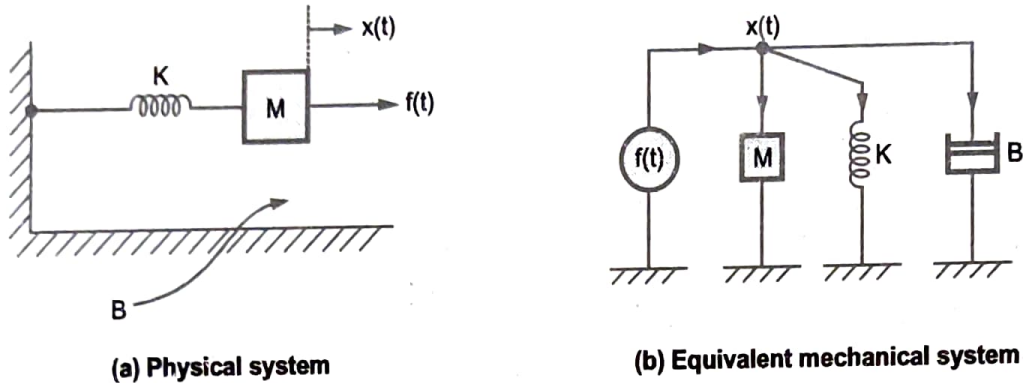

Fig. 4.7.1

The equilibrium equation will be,

$$f(t) = M \frac{d^2 x(t)}{dt^2} + K x(t) + B \frac{dx(t)}{dt}$$

Taking Laplace, $F(s) = Ms^2 X(s) + K X(s) + Bs X(s) = X(s)[Ms^2 + K + Bs]$... (1)

i) **Force-Voltage Method :** Use the analogous terms as,

$$M \rightarrow L, \quad B \rightarrow R, \quad K \rightarrow \frac{1}{C}, \quad x \rightarrow q, \quad \frac{dx}{dt} \rightarrow \frac{dq}{dt} \rightarrow i, \quad x \rightarrow \int idt, \quad \frac{d^2 x}{dt^2} = \frac{di}{dt}$$

All quantities are expressed in terms of current i.

$$v(t) = L \frac{di}{dt} + \frac{1}{C} \int idt + Ri \quad \dots (2)$$

$$\therefore V(s) = sL I(s) + \frac{I(s)}{sC} + I(s)R \quad \dots (3)$$

Simulate using loop method :

Analogous to K is a capacitor C but its value is proportional to 1/K hence it is indicated by writing (1/K) in the bracket near C. This is shown in the Fig. 4.7.2 (a).

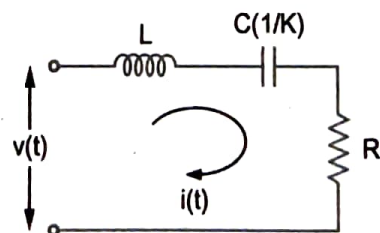

Fig. 4.7.2 (a)

In F-V analogy, the quantities which are under the same displacement in mechanical system, carry the same current in analogous electrical system.

ii) **Force-Current Method** : Use the analogous terms as,

$$M \rightarrow C, B \rightarrow \frac{1}{R}, K \rightarrow \frac{1}{L}, x \rightarrow \phi, \frac{dx}{dt} \rightarrow \frac{d\phi}{dt} \rightarrow v(t), x \rightarrow \int v(t)dt, \frac{d^2x}{dt^2} = \frac{dv(t)}{dt}$$

All quantities are expressed in terms of voltage v .

$$\therefore i(t) = C \frac{dv(t)}{dt} + \frac{1}{R} v(t) + \frac{1}{L} \int v(t)dt \quad \dots (4)$$

$$\therefore I(s) = sCV(s) + \frac{1}{R} V(s) + \frac{1}{sL} V(s) \quad \dots (5)$$

Simulate using node method :

Analogous to K is an inductor L while to B is a resistor R . But their values are proportional to reciprocals of K and B respectively. This is indicated by writing $(1/K)$ and $(1/B)$ in the brackets near L and R respectively in the Fig. 4.7.2 (b).

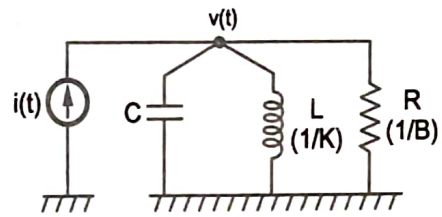

Fig. 4.7.2 (b)

In F-I analogy, the quantities which are under the same displacement in mechanical system, have the same voltage across them in analogous electrical system.

Key Point The equivalent mechanical system and the F-I analogous system are exactly identical as both are drawn based on node basis.

Example 4.7.2 Construct mathematical model for the mechanical system shown in Fig. 4.7.3. Then draw electrical equivalent circuit based on F-V analogy.

July-16, Marks 8

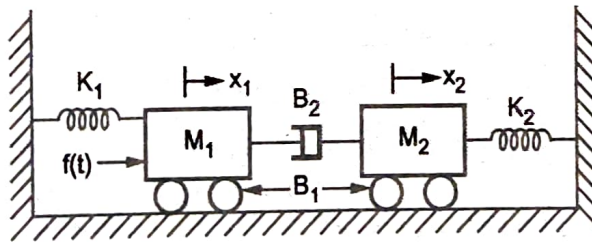

Fig. 4.7.3

Solution : M_1 , K_1 and B_1 are under x_1 as K_1 and B_1 are with respect to fixed support. B_2 is between x_1 and x_2 .

M_2 , K_2 and B_1 are under x_2 as K_2 and B_1 are with respect to fixed support. The equivalent mechanical system is shown in the Fig. 4.7.3 (a).

Review Questions

- Discuss the force current analogy in brief. State the analogous terms based on force-current analogy.
- Derive the electrical analogous quantities for the mechanical quantities using Force-voltage analog.

Jan.-11, Marks 5

4.7 Steps to Solve Problems on Analogous Systems

Aug-97, 10, Dec.-98, 11, April-99, March-02, Feb.-04, July-05,06,08,09,10,11,12,13,14,15,16,
Jan.-06,07,09,10,14,15,16

Step 1 : Identify all the displacements due to the applied force. The elements spring and friction between two moving surfaces cause change in displacement.

Step 2 : Draw the equivalent mechanical system based on node basis. The elements under same displacement will get connected in parallel under that node. Each displacement is represented by separate node. Element causing change in displacement (either friction or spring) is always between the two nodes.

Step 3 : Write the equilibrium equations. At each node algebraic sum of all the forces acting at the node is zero.

Step 4 : In F-V analogy, use following replacements and rewrite equations,

$$F \rightarrow V, \quad M \rightarrow L, \quad B \rightarrow R, \quad K \rightarrow 1/C, \quad x \rightarrow q, \quad \dot{x} \rightarrow i \text{ (current)}, \quad x \rightarrow \int i \, dt$$

Step 5 : Simulate the equations using loop method. Number of displacements equal to number of loop currents.

Step 6 : In F-I analogy, use following replacements and rewrite equations,

$$F \rightarrow I, \quad M \rightarrow C, \quad B \rightarrow 1/R, \quad K \rightarrow 1/L, \quad x \rightarrow \phi, \quad \dot{x} = e \text{ (e.m.f.)}, \quad x \rightarrow \int e \, dt$$

Step 7 : Simulate the equations using node basis. Number of displacements equal to number of node voltages. Infact the system will be exactly same as equivalent mechanical system obtained in step 2 with appropriate replacements.

Example 4.7.1 For the physical system shown draw its equivalent system and write equilibrium equations. Hence draw its electrical analogous circuits based on
i) Force - Voltage ii) Force - Current method.

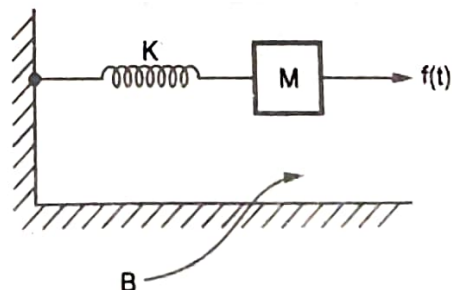

Solution : Mass 'M' will displace by amount 'x' and as spring is connected to fixed support and friction 'B' is also with respect to fixed support, both K and B will be under influence of 'x' only. Now its equivalent system will contain one node and as all elements are under influence of x(t) alone, must be connected in parallel under that node.

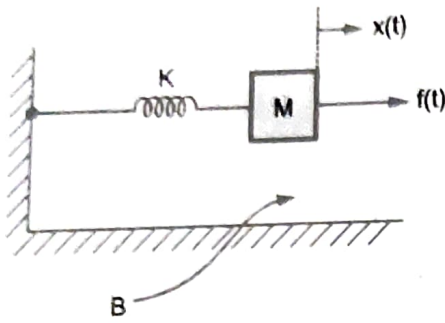

(a) Physical system

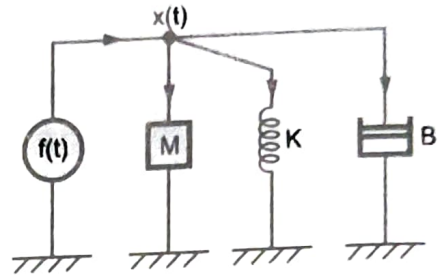

(b) Equivalent mechanical system

Fig. 4.7.1

The equilibrium equation will be,

$$f(t) = M \frac{d^2 x(t)}{dt^2} + K x(t) + B \frac{dx(t)}{dt}$$

Taking Laplace, $F(s) = Ms^2 X(s) + K X(s) + Bs X(s) = X(s)[Ms^2 + K + Bs]$... (1)

i) **Force-Voltage Method :** Use the analogous terms as,

$$M \rightarrow L, B \rightarrow R, K \rightarrow \frac{1}{C}, x \rightarrow q, \frac{dx}{dt} \rightarrow \frac{dq}{dt} \rightarrow i, x \rightarrow \int idt, \frac{d^2x}{dt^2} = \frac{di}{dt}$$

All quantities are expressed in terms of current i.

$$v(t) = L \frac{di}{dt} + \frac{1}{C} \int idt + Ri \quad \dots (2)$$

$$\therefore V(s) = sL I(s) + \frac{I(s)}{sC} + I(s)R \quad \dots (3)$$

Simulate using loop method :

Analogous to K is a capacitor C but its value is proportional to 1/K hence it is indicated by writing (1/K) in the bracket near C. This is shown in the Fig. 4.7.2 (a).

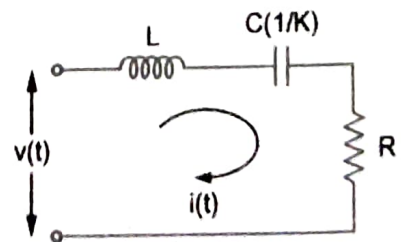

Fig. 4.7.2 (a)

In F-V analogy, the quantities which are under the same displacement in mechanical system, carry the same current in analogous electrical system.

i) **Force-Current Method** : Use the analogous terms as,

$$M \rightarrow C, \quad B \rightarrow \frac{1}{R}, \quad K \rightarrow \frac{1}{L}, \quad x \rightarrow \phi, \quad \frac{dx}{dt} \rightarrow \frac{d\phi}{dt} \rightarrow v(t), \quad x \rightarrow \int v(t)dt, \quad \frac{d^2x}{dt^2} = \frac{dv(t)}{dt}$$

All quantities are expressed in terms of voltage v .

$$i(t) = C \frac{dv(t)}{dt} + \frac{1}{R} v(t) + \frac{1}{L} \int v(t)dt \quad \dots (4)$$

$$I(s) = sCV(s) + \frac{1}{R} V(s) + \frac{1}{sL} V(s) \quad \dots (5)$$

Simulate using node method :

Analogous to K is an inductor L while to B is a resistor R . But their values are proportional to reciprocals of K and B respectively. This is indicated by writing $(1/K)$ and $(1/B)$ in the brackets near L and R respectively in the Fig. 4.7.2 (b).

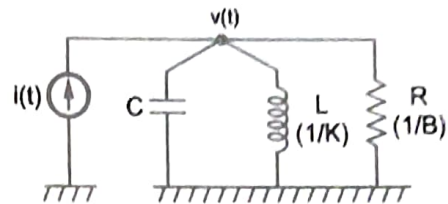

Fig. 4.7.2 (b)

In F-I analogy, the quantities which are under the **same displacement** in mechanical system, have the **same voltage** across them in analogous electrical system.

Key Point The equivalent mechanical system and the F-I analogous system are exactly identical as both are drawn based on node basis.

Example 4.7.2 Construct mathematical model for the mechanical system shown in Fig. 4.7.3. Then draw electrical equivalent circuit based on F-V analogy.

July-16, Marks 8

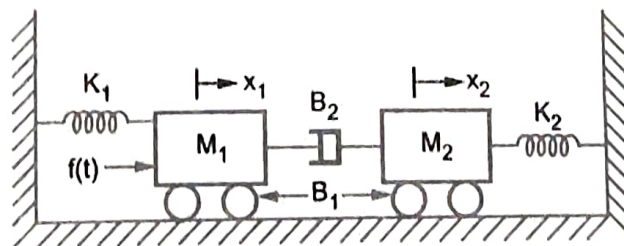

Fig. 4.7.3

Solution : M_1 , K_1 and B_1 are under x_1 as K_1 and B_1 are with respect to fixed support. B_2 is between x_1 and x_2 .

M_2 , K_2 and B_1 are under x_2 as K_2 and B_1 are with respect to fixed support. The equivalent mechanical system is shown in the Fig. 4.7.3 (a).

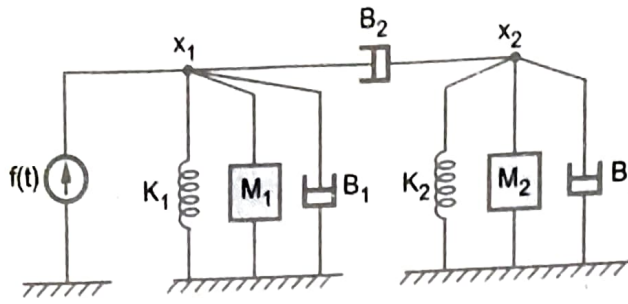

Fig. 4.7.3 (a)

The equilibrium equations at two nodes are,

$$f(t) = M_1 \frac{d^2x_1}{dt^2} + B_1 \frac{dx_1}{dt} + K_1 x_1 + B_2 \frac{d(x_1 - x_2)}{dt}$$

$$0 = B_2 \frac{d(x_2 - x_1)}{dt} + M_2 \frac{d^2x_2}{dt^2} + B_1 \frac{dx_2}{dt} + K_2 x_2$$

F-V analogy : $M \rightarrow L, B \rightarrow R, K \rightarrow \frac{1}{C}, x \rightarrow q, \frac{dx}{dt} \rightarrow i, x \rightarrow \int i dt, \frac{d^2x}{dt^2} \rightarrow \frac{di}{dt}$

$$v(t) = L_1 \frac{di_1}{dt} + R_1 i_1 + \frac{1}{C_1} \int i_1 dt + R_2 (i_1 - i_2)$$

$$0 = R_2 (i_2 - i_1) + L_2 \frac{di_2}{dt} + R_1 i_2 + \frac{1}{C_2} \int i_2 dt$$

Using loop basis, F-V analogy network can be drawn as shown in the Fig. 4.7.3 (b).

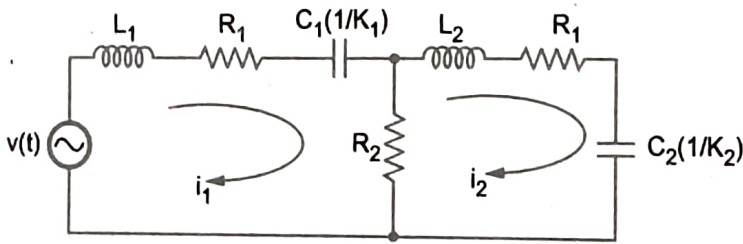

Fig. 4.7.3 (b)

Example 4.7.3 For a mechanical system shown in Fig. 4.7.4 obtain force voltage analogous electrical network. July-15, Marks 8

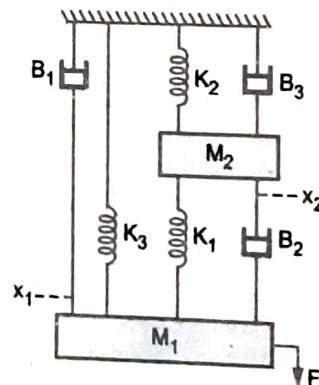

Fig. 4.7.4

Solution : As K_3 and B_1 are between M_1 and fixed support, M_1 , B_1 and K_3 are under displacement x_1 . K_1 and B_2 are between x_1 and x_2 . While M_2 , K_2 and B_3 are under displacement x_2 . The equivalent mechanical system is shown in the Fig. 4.7.4 (a).

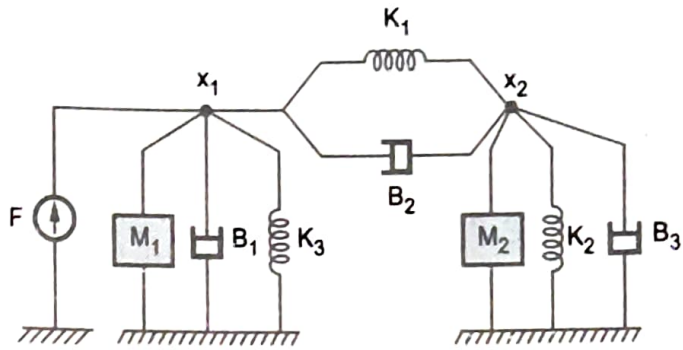

Fig. 4.7.4 (a)

The equilibrium equations are,

$$F = M_1 \frac{d^2x_1}{dt^2} + B_1 \frac{dx_1}{dt} + K_3x_1 + K_1(x_1 - x_2) + B_2 \frac{d(x_1 - x_2)}{dt} \quad \dots(1)$$

$$0 = K_1(x_2 - x_1) + B_2 \frac{d(x_1 - x_2)}{dt} + M_2 \frac{d^2x_2}{dt^2} + K_2x_2 + B_3 \frac{dx_2}{dt} \quad \dots(2)$$

F-V analogy : $M \rightarrow L, B \rightarrow R, K \rightarrow \frac{1}{C}, \frac{dx}{dt} \rightarrow i, x \rightarrow \int i dt, \frac{d^2x}{dt^2} \rightarrow \frac{di}{dt}$

$$\therefore V = L_1 \frac{di_1}{dt} + R_1i_1 + \frac{1}{C_3} \int i_1 dt + \frac{1}{C_1} \int (i_1 - i_2) dt + R_2 (i_1 - i_2) \quad \dots(3)$$

$$\therefore 0 = \frac{1}{C_1} \int (i_2 - i_1) dt + R_2 (i_2 - i_1) + L_2 \frac{di_2}{dt} + \frac{1}{C_2} \int i_2 dt + R_3 i_2 \quad \dots(4)$$

Simulating equations on loop basis, F-V analogous circuit is as shown in the Fig. 4.7.4(b).

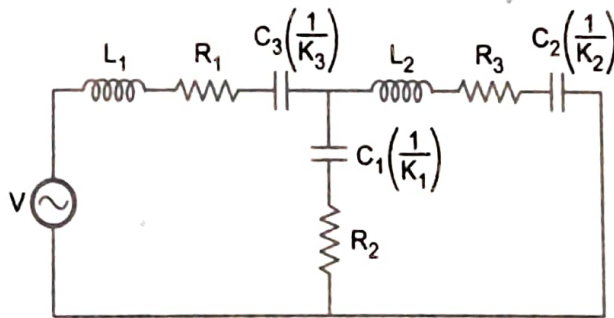

Fig. 4.7.4 (b)

Example 4.7.4 Draw the electrical network based on torque current analogy and give all the performance equation for the Fig. 4.7.5.

July-14, 15, Marks 8

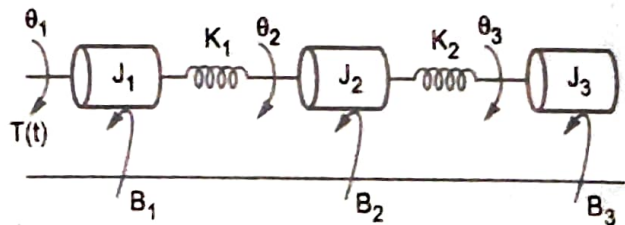

Fig. 4.7.5

Solution : J_1 and B_1 are under θ_1 . K_1 is between θ_1 and θ_2 .

J_2 and B_2 are under θ_2 . K_2 is between θ_2 and θ_3 .

J_3 and B_3 are under θ_3 .

The equivalent mechanical system is shown in the Fig. 4.7.5 (a).

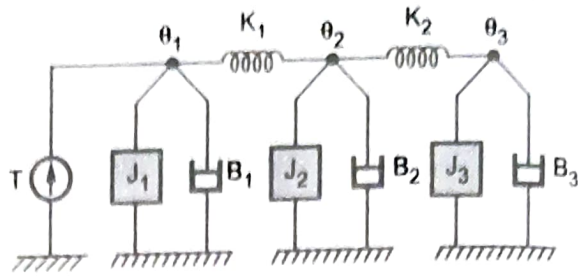

Fig. 4.7.5 (a)

The equilibrium equations are,

$$T = J_1 \frac{d^2\theta_1}{dt^2} + B_1 \frac{d\theta_1}{dt} + K_1(\theta_1 - \theta_2)$$

$$0 = K_1(\theta_2 - \theta_1) + J_2 \frac{d^2\theta_2}{dt^2} + B_2 \frac{d\theta_2}{dt} + K_2(\theta_2 - \theta_3)$$

$$0 = K_2(\theta_3 - \theta_2) + J_3 \frac{d^2\theta_3}{dt^2} + B_3 \frac{d\theta_3}{dt}$$

T-I analogy : $M \rightarrow C$, $B \rightarrow \frac{1}{R}$, $K \rightarrow \frac{1}{L}$, $\frac{d\theta}{dt} \rightarrow v$, $\theta \rightarrow \int v dt$, $\frac{d^2\theta}{dt^2} \rightarrow \frac{dv}{dt}$

$$I = C_1 \frac{dv_1}{dt} + \frac{v_1}{R_1} + \frac{1}{L_1} \int (v_1 - v_2) dt$$

$$0 = \frac{1}{L_1} \int (v_2 - v_1) dt + C_2 \frac{dv_2}{dt} + \frac{v_2}{R_2} + \frac{1}{L_2} \int (v_2 - v_3) dt$$

$$0 = \frac{1}{L_2} \int (v_3 - v_2) dt + C_3 \frac{dv_3}{dt} + \frac{v_3}{R_3}$$

Based on node basis T-I analogous circuit is shown in the Fig. 4.7.5 (b).

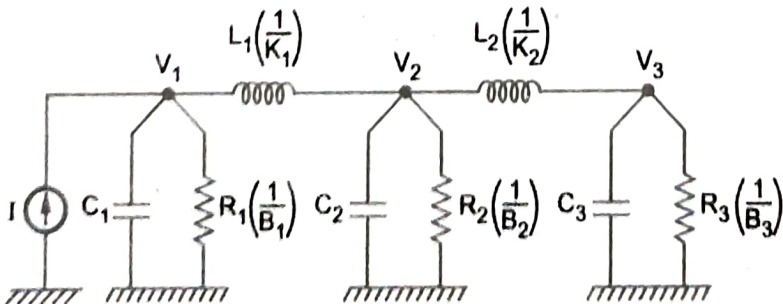

Fig. 4.7.5 (b)

Example 4.7.5 Draw the F-V and F-I analogous circuits for the mechanical system shown in Fig. 4.7.6 with necessary equations.

Jan. 15, Marks 8

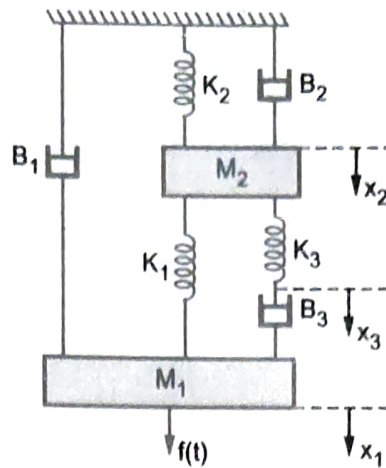

Fig. 4.7.6

Solution : M_1 and B_1 are under the displacement x_1 . K_1 is between x_1 and x_2 while B_3 is between x_1 and x_3 . K_3 is between x_3 and x_2 . The mass M_2 , K_2 and B_2 are under x_2 . Hence the equivalent mechanical system is as shown in the Fig. 4.7.6 (a).

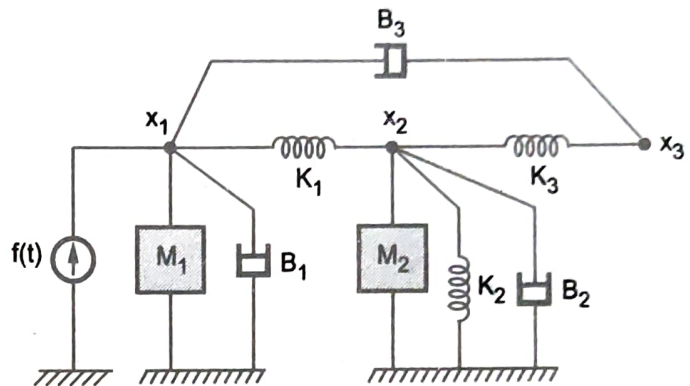

Fig. 4.7.6 (a)

The equilibrium equations are,

$$f(t) = M_1 \frac{d^2 x_1}{dt^2} + B_1 \frac{dx_1}{dt} + K_1 (x_1 - x_2) + B_3 \frac{d(x_1 - x_3)}{dt} \quad \dots(1)$$

$$0 = K_1 (x_2 - x_1) + M_2 \frac{d^2 x_2}{dt^2} + B_2 \frac{dx_2}{dt} + K_2 x_2 + K_3 (x_2 - x_3) \quad \dots(2)$$

$$0 = K_3 (x_3 - x_2) + B_3 \frac{d(x_3 - x_1)}{dt} \quad \dots(3)$$

F-V analogy : $M \rightarrow L$, $B \rightarrow R$, $K \rightarrow \frac{1}{C}$, $x \rightarrow q$, $\frac{dx}{dt} \rightarrow i$, $x \rightarrow \int i$, $\frac{d^2 x}{dt^2} \rightarrow \frac{di}{dt}$

$$\therefore V(t) = L_1 \frac{di_1}{dt} + R_1 i_1 + \frac{1}{C_1} \int (i_1 - i_2) dt + R_3 (i_1 - i_3)$$

$$0 = \frac{1}{C_1} \int (i_2 - i_1) dt + L_2 \frac{di_2}{dt} + R_2 i_2 + \frac{1}{C_2} \int i_2 dt + \frac{1}{C_3} \int (i_2 - i_3) dt$$

$$0 = \frac{1}{C_3} \int (i_3 - i_2) dt + R_3 (i_3 - i_1)$$

Hence F-V analogous network is as shown in the Fig. 4.7.6 (b).

F-I analogy : $M \rightarrow C, B \rightarrow \frac{1}{R}, K \rightarrow \frac{1}{L}$
 $x \rightarrow \phi, \frac{dx}{dt} \rightarrow v, x \rightarrow \int v dt, \frac{d^2x}{dt^2} \rightarrow \frac{dv}{dt}$

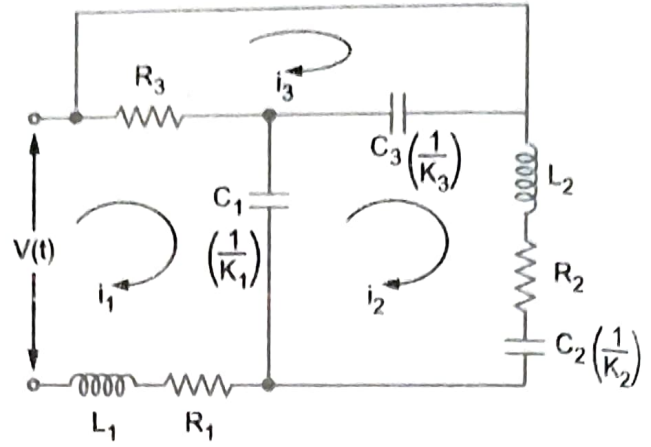

Fig. 4.7.6 (b)

$$\therefore I(t) = C_1 \frac{dv_1}{dt} + \frac{1}{R_1} v_1 + \frac{1}{L_1} \int (v_1 - v_2) dt + \frac{1}{R_3} (v_1 - v_3)$$

$$0 = \frac{1}{L_1} \int (v_2 - v_1) dt + C_2 \frac{dv_2}{dt} + \frac{1}{R_2} v_2 + \frac{1}{L_2} \int v_2 dt + \frac{1}{L_3} \int (v_2 - v_3) dt$$

$$\therefore 0 = \frac{1}{L_3} \int (v_3 - v_2) dt + \frac{1}{R_3} (v_3 - v_1)$$

Hence F-I analogous network is shown in the Fig. 4.7.6 (c).

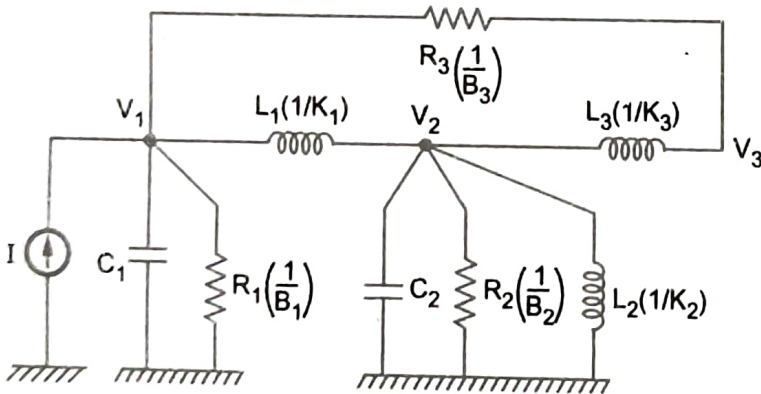

Fig. 4.7.6 (c)

Example 4.7.6 For the rotational mechanical system shown draw the torque-voltage analogous circuit for Fig. 4.7.7 (b).

Jan-15, Marks 8

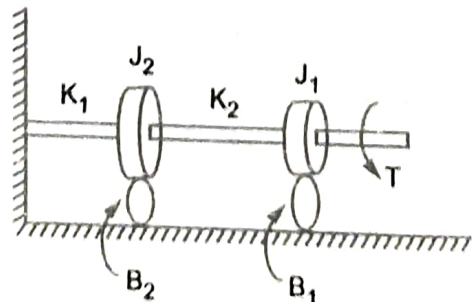

Fig. 4.7.7

Solution : There are two displacements θ_1 and θ_2 of J_1 and J_2 as shown in the Fig. 4.7.7 (a). J_1 and B_1 are under the displacement θ_1 , K_2 is between θ_1 and θ_2 while J_2 , B_2 and K_1 are under θ_2 . Hence equivalent mechanical system is as shown in the Fig. 4.7.7 (b).

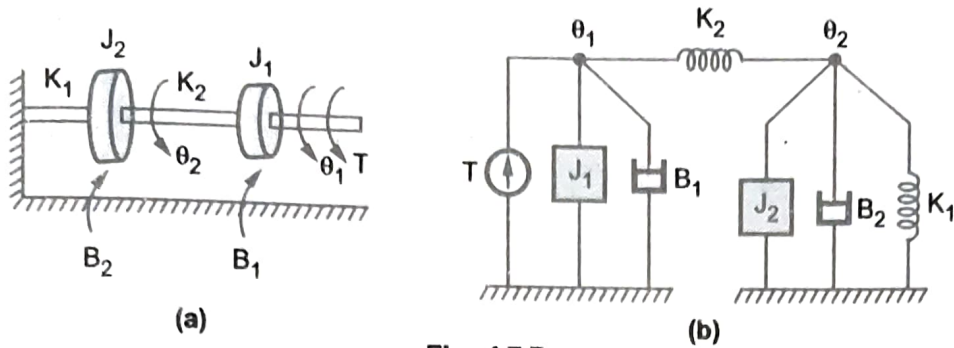

Fig. 4.7.7

$$T = J_1 \frac{d^2\theta_1}{dt^2} + B_1 \frac{d\theta_1}{dt} + K_2 (\theta_1 - \theta_2) \quad \dots(1)$$

$$0 = K_2(\theta_2 - \theta_1) + J_2 \frac{d^2\theta_2}{dt^2} + B_2 \frac{d\theta_2}{dt} + K_1\theta_2 \quad \dots(2)$$

For T-V analogy, $J \rightarrow L$, $B \rightarrow R$, $K \rightarrow \frac{1}{C}$, $\frac{d\theta}{dt} \rightarrow i$, $\theta \rightarrow \int i dt$, $\frac{d^2\theta}{dt^2} \rightarrow \frac{di}{dt}$

$$\therefore V = L_1 \frac{di_1}{dt} + R_1 i_1 + \frac{1}{C_2} \int (i_1 - i_2) dt \quad \dots(3)$$

$$0 = \frac{1}{C_2} \int (i_2 - i_1) dt + L_2 \frac{di_2}{dt} + R_2 i_2 + \frac{1}{C_1} \int i_2 dt \quad \dots(4)$$

Based on the loop basis the F-V analogous network is shown in the Fig. 4.7.7 (c).

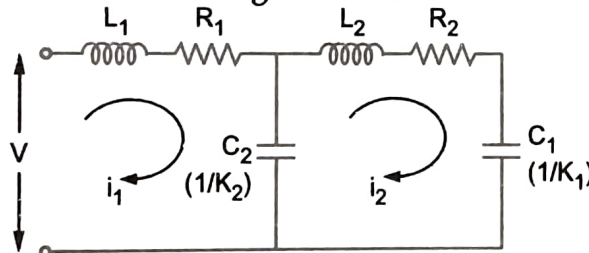

Fig. 4.7.7 (c)

Example 4.7.7 For the electromechanical system shown in Fig. 4.7.8 find the transfer function $\frac{X(S)}{E(S)}$.

Jan.-14, Marks 8

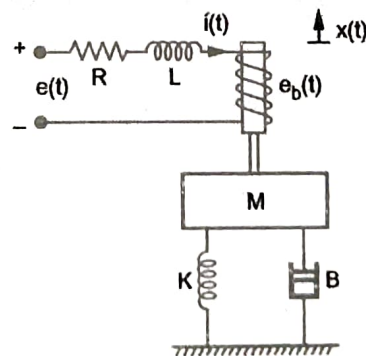

Fig. 4.7.8

Solution : The electric system is shown in the Fig. 4.7.8 (a).

$$e(t) = i(t) R + L \frac{di(t)}{dt} + e_b(t)$$

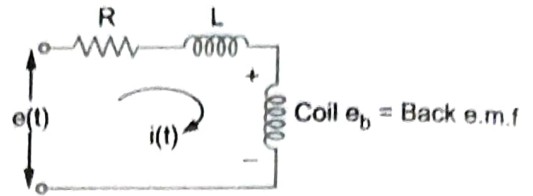

Fig. 4.7.8 (a)

Taking Laplace, $E(s) = I(s) [R + sL] + E_b(s)$... (1)

Back e.m.f. $\propto \frac{dx}{dt}$ i.e. $e_b(t) \propto \frac{dx}{dt}$ i.e. $e_b(t) = K_b \frac{dx}{dt}$

$\therefore E_b(s) = K_b s X(s)$ [$K_b =$ Back e.m.f. constant] ... (2)

Consider the mechanical system shown in the Fig. 4.7.8 (b).

$f(t) \propto i(t)$ i.e. $f(t) = K_i i(t)$

$\therefore F(s) = K_i I(s)$... (3) [$K_i =$ constant]

$f(t) = M \frac{d^2 x(t)}{dt^2} + B \frac{dx(t)}{dt} + K x(t)$ i.e. $F(s) = [Ms^2 + Bs + K] X(s)$... (4)

$\therefore K_i I(s) = [Ms^2 + Bs + K] X(s)$... (5)

Use $I(s)$ from (5) in (1), $E(s) = \frac{[Ms^2 + Bs + K]}{K_i} X(s) [R + sL] + E_b(s)$

$\therefore E(s) = \frac{(Ms^2 + Bs + K)}{K_i} [R + sL] X(s) + K_b s X(s)$... from (2)

$$\frac{X(s)}{E(s)} = \frac{K_i}{(Ms^2 + Bs + K) (R + sL) + K_i K_b s}$$

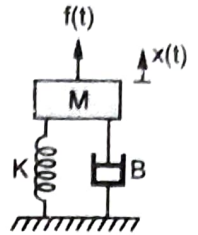

Fig. 4.7.8 (b)

Example 4.7.8 For the system shown in Fig. 4.7.9 write its mechanical network and obtain mathematical model and electrical analogous based on force-current analogy.

July-10, 13, Marks 8

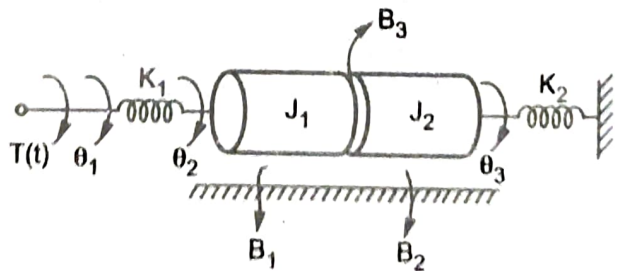

Fig. 4.7.9

Solution : The spring K_1 is between θ_1 and θ_2 . J_1 and B_1 are under the displacement θ_2 . B_3 is between θ_2 and θ_3 while J_2 , B_2 and K_2 are under the displacement θ_3 . The equivalent mechanical network is shown in the Fig. 4.7.9 (a).

The equilibrium equations at the three nodes are,

$$T(t) = K_1(\theta_1 - \theta_2) \quad \dots (1)$$

$$0 = K_1(\theta_2 - \theta_1) + J_1 \frac{d^2\theta_2}{dt^2} + B_1 \frac{d\theta_2}{dt} + B_3 \frac{d(\theta_2 - \theta_3)}{dt} \quad \dots (2)$$

$$0 = B_3 \frac{d(\theta_3 - \theta_2)}{dt} + J_2 \frac{d^2\theta_3}{dt^2} + B_2 \frac{d\theta_3}{dt} + K_2 \theta_3 \quad \dots (3)$$

For F - I analogy, use $J \rightarrow C$, $B \rightarrow \frac{1}{R}$, $K \rightarrow \frac{1}{L}$, $\theta \rightarrow \phi$, $\frac{d\theta}{dt} \rightarrow \frac{d\phi}{dt} \rightarrow v(t)$,

$\theta \rightarrow \int v(t) dt$, $\frac{d^2\theta}{dt^2} \rightarrow \frac{dv(t)}{dt}$ and use in equations (1), (2) and (3).

$$I(t) = \frac{1}{L_1} \int (V_1 - V_2) dt \quad \dots (4)$$

$$0 = \frac{1}{L_1} \int (V_2 - V_1) dt + C_1 \frac{dV_2}{dt} + \frac{1}{R_1} V_2 + \frac{1}{R_3} (V_2 - V_3) \quad \dots (5)$$

$$0 = \frac{1}{R_3} (V_3 - V_2) + C_2 \frac{dV_3}{dt} + \frac{1}{R_2} V_3 + \frac{1}{L_2} \int V_3 dt \quad \dots (6)$$

From the equations (4), (5) and (6), the F-I analogous network is shown in the Fig. 4.7.9 (b).

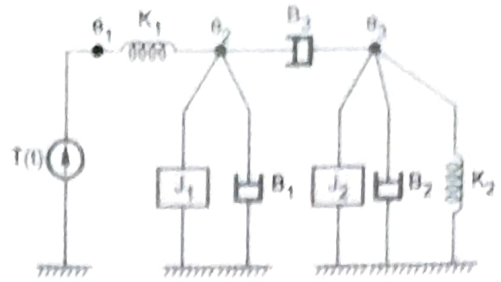

Fig. 4.7.9 (a)

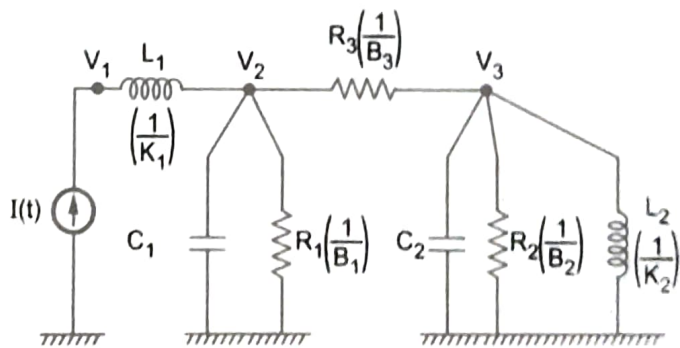

Fig. 4.7.9 (b)

Example 4.7.9 Write the differential equations of performance for the mechanical system shown in Fig. 4.7.10. Draw its F-V analogous circuit.

Dec. 98, July 08, 12, Marks 8

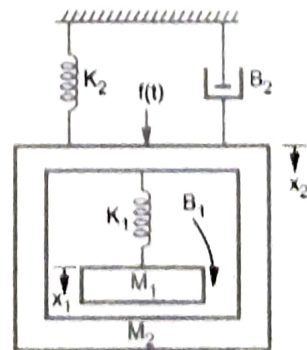

Fig. 4.7.10

Solution : The mass M_1 is under the influence of x_1 . The spring K_1 and B_1 are between x_1 and x_2 . While M_2 , K_2 and B_2 are under the influence of x_2 . The equivalent mechanical system is shown in the Fig. 4.7.10 (a). The equilibrium equations are,

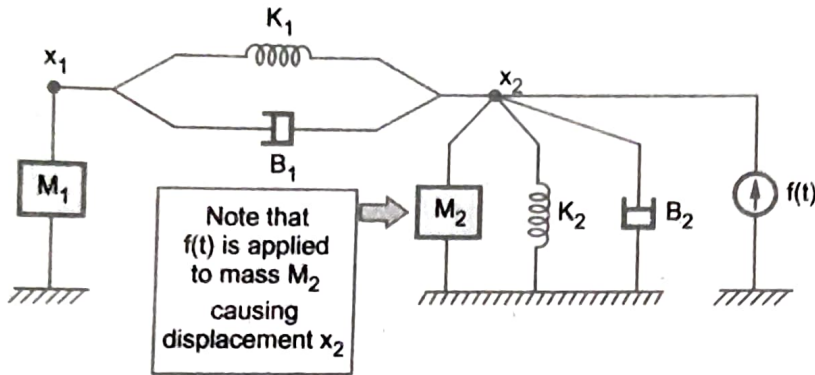

Fig. 4.7.10 (a)

$$0 = M_1 \frac{d^2 x_1}{dt^2} + K_1(x_1 - x_2) + B_1 \frac{d(x_1 - x_2)}{dt} \quad \dots (1)$$

$$f(t) = K_1(x_2 - x_1) + B_1 \frac{d(x_2 - x_1)}{dt} + M_2 \frac{d^2 x_2}{dt^2} + B_2 \frac{dx_2}{dt} + K_2 x_2 \quad \dots (2)$$

For F-V, $M \rightarrow L$, $B \rightarrow R$, $K \rightarrow \frac{1}{C}$, $x \rightarrow \int i dt$, $\frac{dx}{dt} \rightarrow i$, $\frac{d^2 x}{dt^2} \rightarrow \frac{di}{dt}$

$$\therefore 0 = L_1 \frac{di_1}{dt} + \frac{1}{C_1} \int (i_1 - i_2) dt + R_1 (i_1 - i_2) \quad \dots (3)$$

$$v(t) = \frac{1}{C_1} \int (i_2 - i_1) dt + R_1 (i_2 - i_1) + L_2 \frac{di_2}{dt} + R_2 i_2 + \frac{1}{C_2} \int i_2 dt \quad \dots (4)$$

The F-V analogous circuit is shown in the Fig. 4.7.10 (b).

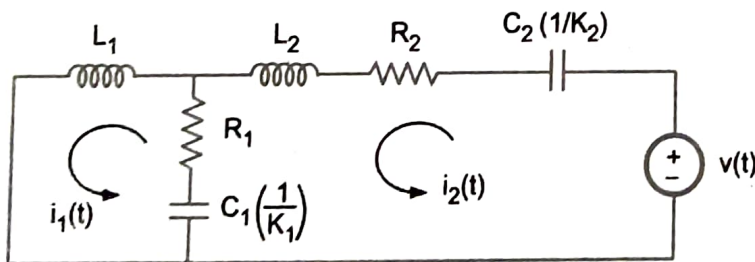

Fig. 4.7.10 (b)

Example 4.7.10 For the system shown in Fig. 4.7.11, find the transfer function $G(S) = \frac{\theta_2(s)}{T(s)}$.

Consider $J_1 = 1 \text{ kgm}^2$, $K_1 = 1 \text{ Nm/rad}$, $K_2 = 1 \text{ Nm/rad}$.

$B_1 = 1 \text{ Nm/rad/sec}$, $B_2 = 1 \text{ Nm/rad/sec}$.

Dec.-11, Marks 6

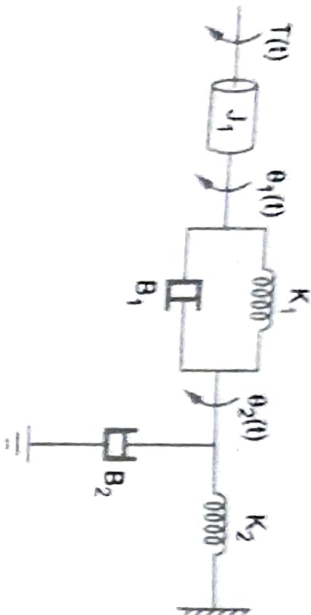

Fig. 4.7.11

Solution : The inertia J_1 is under θ_1 . The K_1 and B_1 are between θ_2 and θ_1 . The K_2 and B_2 are under θ_2 . The equivalent mechanical system is shown in Fig. 1(a). The equations are,

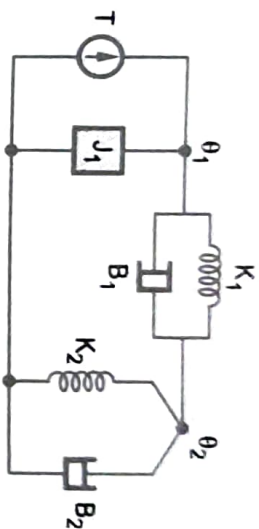

Fig. 4.7.11 (a)

$$T = J_1 \frac{d^2\theta_1}{dt^2} + B_1 \frac{d(\theta_1 - \theta_2)}{dt} + K_1 (\theta_1 - \theta_2) \quad \dots(1)$$

$$0 = K_1(\theta_2 - \theta_1) + B_1 \frac{d(\theta_2 - \theta_1)}{dt} + B_2 \frac{d\theta_2}{dt} + K_2\theta_2 \quad \dots(2)$$

Taking Laplace transform of both the equations,

$$T(s) = [s^2J_1 + sB_1 + K_1] \theta_1(s) - [sB_1 + K_1] \theta_2(s) \quad \dots(3)$$

$$0 = -[sB_1 + K_1] \theta_1(s) + [s(B_1 + B_2) + (K_1 + K_2)] \theta_2(s) \quad \dots(4)$$

$$\therefore \theta_1(s) = \frac{s(B_1 + B_2) + (K_1 + K_2)}{(sB_1 + K_1)} \theta_2(s) \text{ and use in equation (3)}$$

$$\therefore T(s) = \frac{[s^2J_1 + sB_1 + K_1][s(B_1 + B_2) + (K_1 + K_2)]}{(sB_1 + K_1)} \theta_2(s) - [sB_1 + K_1] \theta_2(s)$$

Using the given values,

$$T(s) = \frac{(s^2 + s + 1)(2s + 2)}{(s + 1)} \theta_2(s) - (s + 1) \theta_2(s)$$

$$\therefore \frac{\theta_2(s)}{T(s)} = \frac{1}{2s^2 + s + 1}$$